

More Precision.



optris® CT

Precise noncontact temperature measurement
from -40 to 900°C



FEATURES

- One of the smallest infrared sensors worldwide with 22:1 optical resolution
- Rugged and usable up to 180°C ambient temperature without cooling
- Separate electronics with easy accessible programming keys and LCD backlit display
- Selectable analog output: 0/4-20 mA, 0 - 5 V/0 - 10 V, thermocouple type K or J
- Optional USB, RS485, RS232, CAN, Profibus DP interfaces, relay outputs (2x optically isolated)

General specifications	
Environmental rating	IP 65 (NEMA-4)
Ambient temperature	sensing head: -20 - 180°C (130°C with 2:1) electronics: 0 - 65°C
Storage temperature	sensing head: -40 - 180°C (130°C with 2:1) electronics: -40 - 85°C
Relative humidity	10 - 95 %, non condensing
Vibration (sensor)	IEC 68-2-6: 3 G, 11-200 Hz, any axis
Shock (sensor)	IEC 68-2-27: 50 G, 11 ms, any axis
Weight	sensing head 40 g electronics 420 g
Electrical specifications	
Outputs/analog	channel 1: 0/4 - 20 mA, 0 - 5/10 V, thermocouple J, K channel 2: sensing head temperature (-20 - 180°C as 0 - 5 V or 0 - 10 V), alarm output
Optional:	relay: 2 x 60 V DC/42 V AC _{eff} ; 0.4 A; optically isolated
Outputs/digital (optional)	USB, RS232, RS485, CAN, Profibus DP
Output impedances	mA max. 500 Ω (with 8 - 36 V DC) mV min. 100 kΩ load impedance thermocouple 20 Ω
Inputs	programmable functional inputs for external emissivity adjustment, ambient temperature compensation, trigger (reset of hold functions)
Cable length	1 m (standard), 3 m, 8 m, 15 m
Current draw	max. 100 mA
Power supply	8 - 36 V DC

Measurement specifications	
Temperature range (scalable via programming keys or software)	-40 - 900°C (22:1)
	-40 - 600°C (15:1)
	-40 - 600°C (2:1)
Spectral range	8 - 14 μm
Optical resolution	22:1
	15:1
CF-lens (optional)	2:1
	0.6 mm@10 mm (with 22:1)
	0.8 mm@10 mm (with 15:1) 2.5 mm@23 mm (with 2:1)
System accuracy (at ambient temperature 23 ±5°C)	±1 % or ±1°C ¹
Repeatability (at ambient temperature 23 ±5°C)	±0.5 % or ±0.5°C ¹
Temperature coefficient	0.05 % or 0.05°C/K ^{1,2}
Temperature resolution	0.1°C
Response time	150 ms (95 %)
Emissivity/Gain (adjustable via programming keys or software)	0.100 - 1.100
Transmissivity/Gain (adjustable via programming keys or software)	0.100 - 1.100
Signal processing (parameter adjustable via programming keys or software, respectively)	peak hold, valley hold, average; extended hold function with threshold and hysteresis
Certificate of calibration	optional

¹ whichever is greater

² at sensing head temperature 0 - 180°C (130°C with 2:1)

optris® CT

Optical specifications

22:1 optics

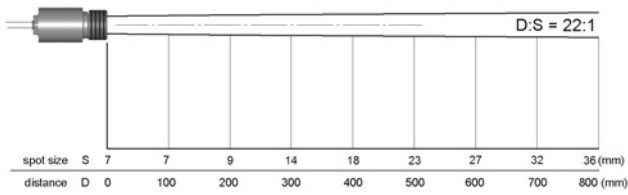

22:1 optics with CF-lens

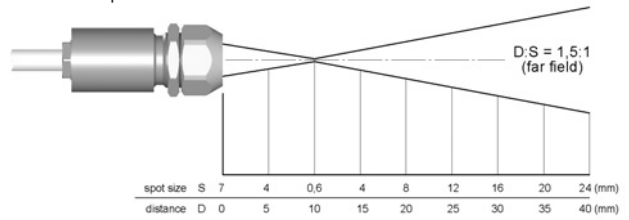

15:1 optics

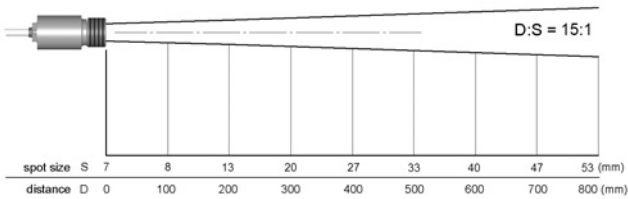

15:1 optics with CF-lens

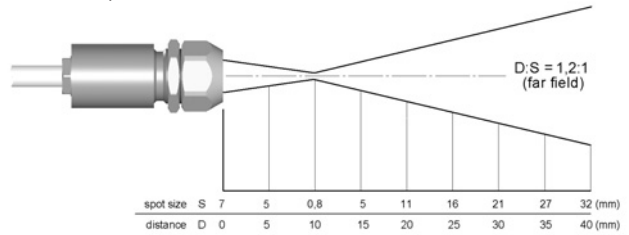

2:1 optics

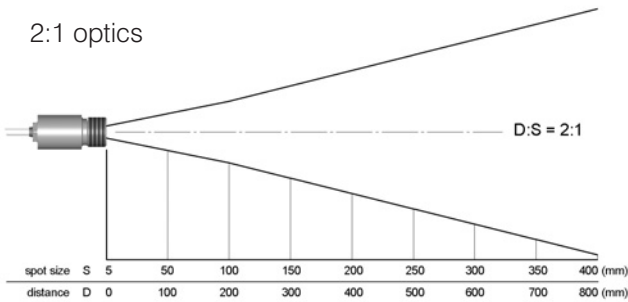

2:1 optics with CF-lens

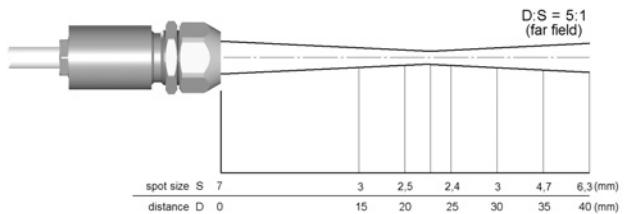

Dimensions

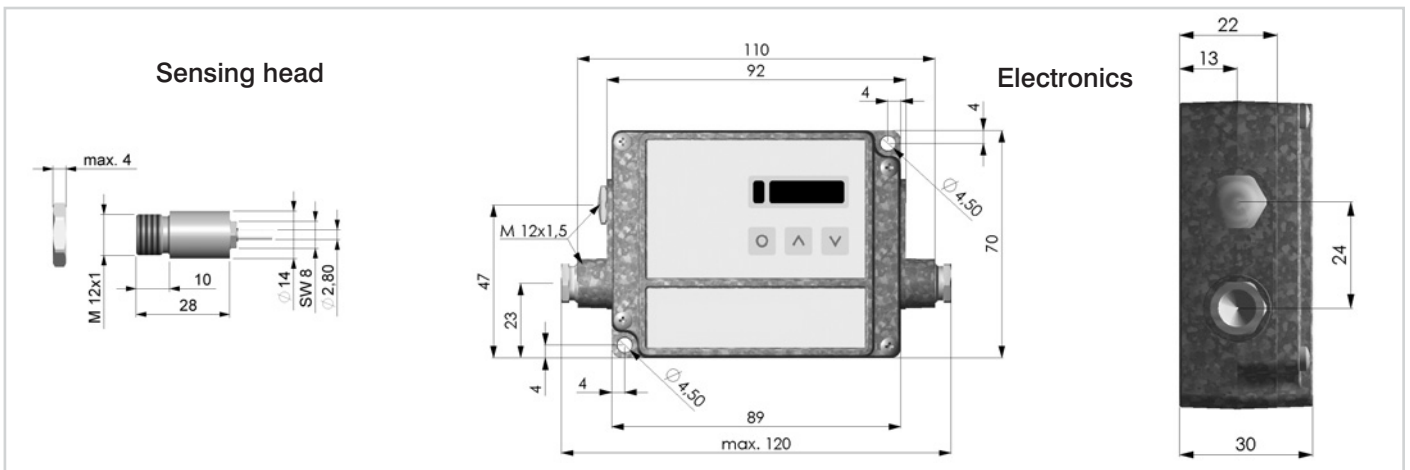

CompactConnect Software

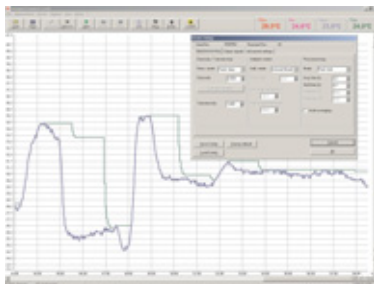

- Software for easy sensor setup and remote controlling, supports multi tasking
- Graphic display for temperature trends and automatic data logging for analysis and documentation with 1 ms response time
- Adjustment of signal processing functions and programming of outputs and functional inputs of the sensor
- Automatic emissivity adjustment
- The software CompactConnect allows to customize the CT laser to application needs of the user

MICRO-EPSILON

8120 Brownleigh Dr.
Raleigh, NC 27617 / USA

Phone +1/919/787-9707
Fax +1/919/787-9706

info@micro-epsilon.us
www.micro-epsilon.us

certified DIN EN ISO 9001 : 2000
modifications reserved /CT-DS-E2007-07-E

A member of micro-epsilon group.

